













# YGW40N120T1B1

1200V / 40A Trench Field Stop IGBT

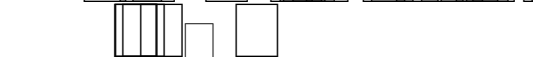
## FEATURES

- 
- 
- 
- 
- 
- 
- 
- 
- 
- 
- 
- 
- 

$V_{CE}$	1200	V
$I_C$	40	A
$V_{CE(SAT)} I_C=40A$	1.7	V

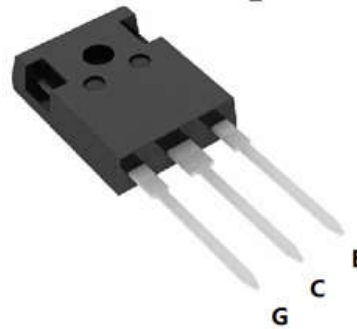
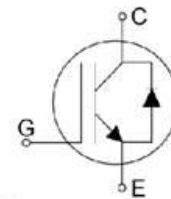



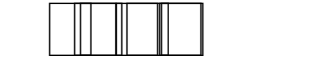

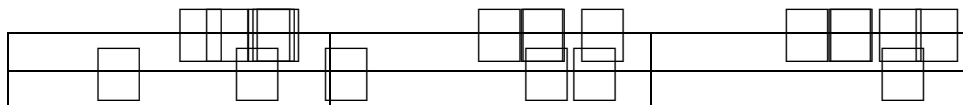





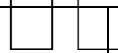

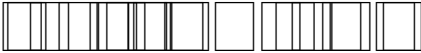





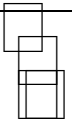



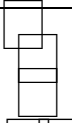









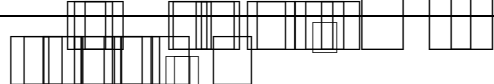











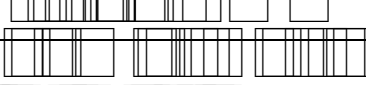







## APPLICATION





















- 
- 

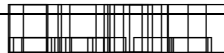

**Maximum Ratings**

			
			
			
			
		$\pm$ 	
			
			
			
			
			
			
			
			

**Thermal Resistance**

**Electrical Characteristics of the IGBT (**

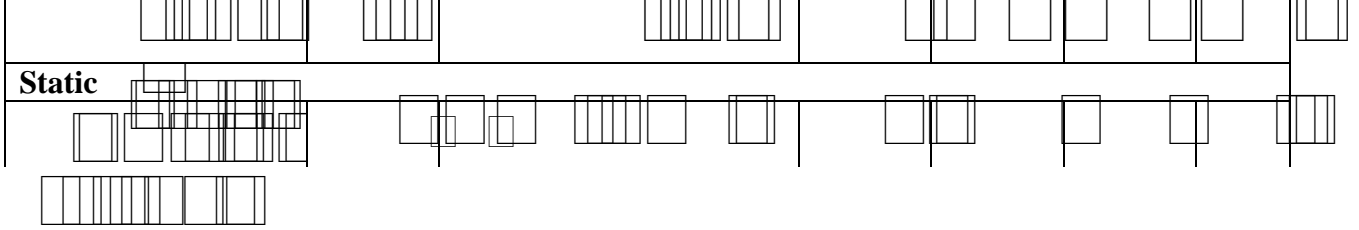

**Switching Characteristic, Inductive Load**

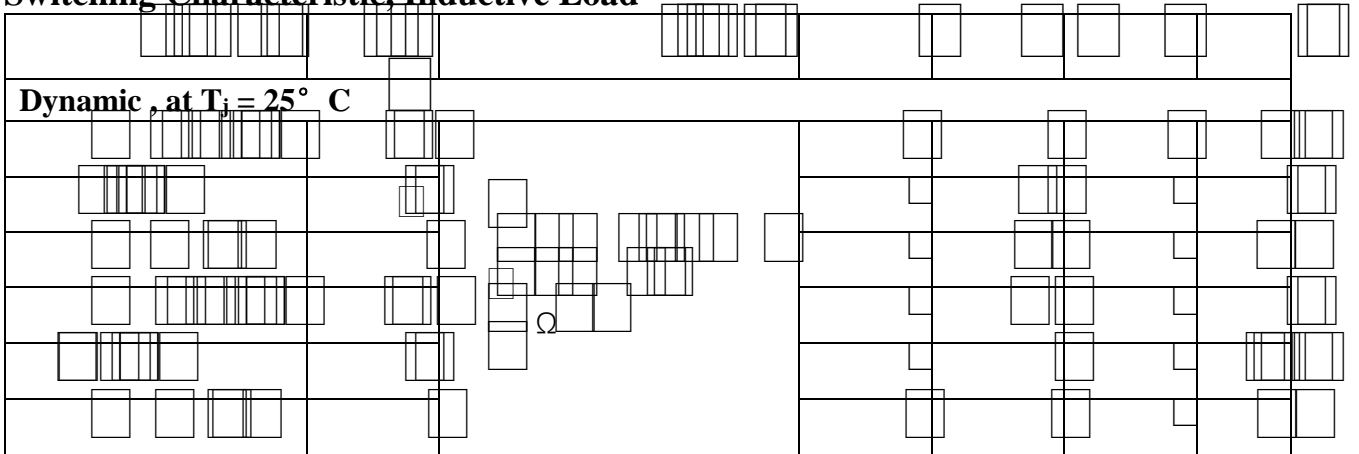

**Electrical Characteristics of the DIODE (**

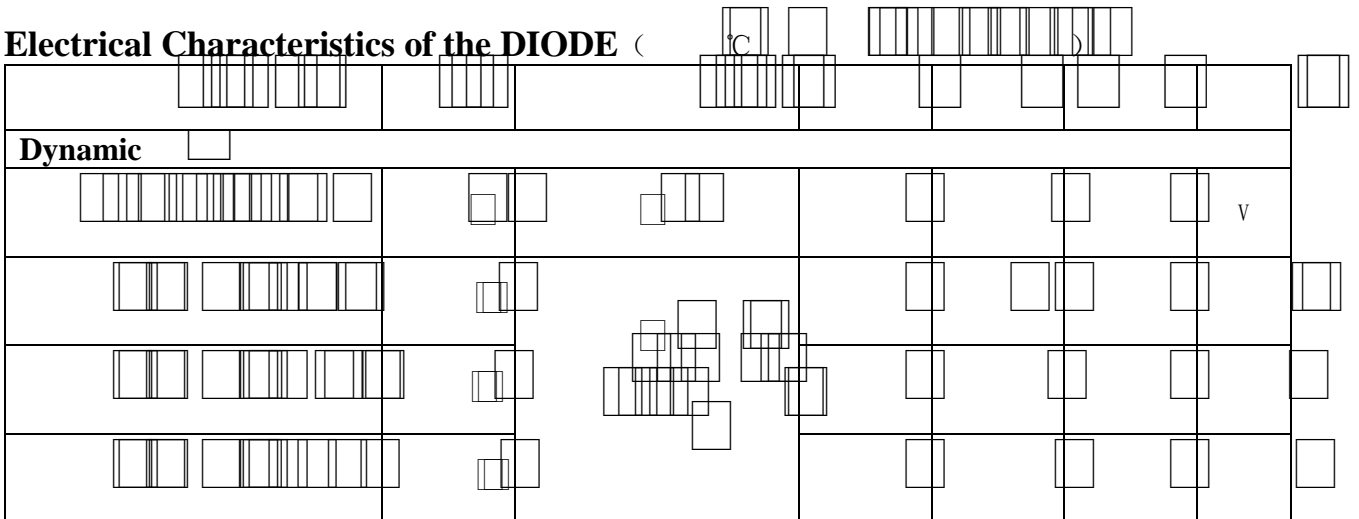





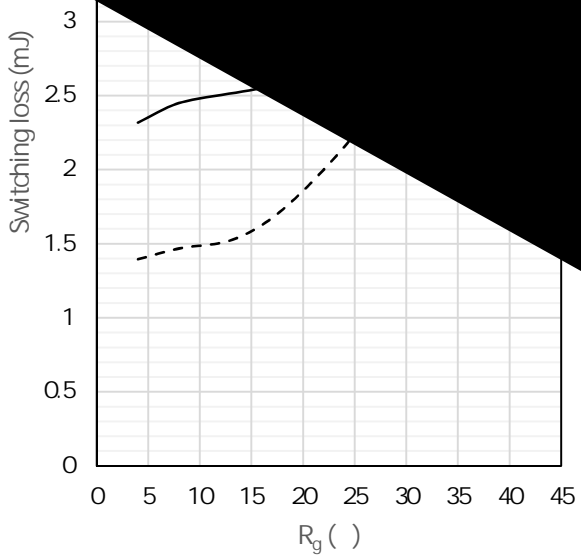

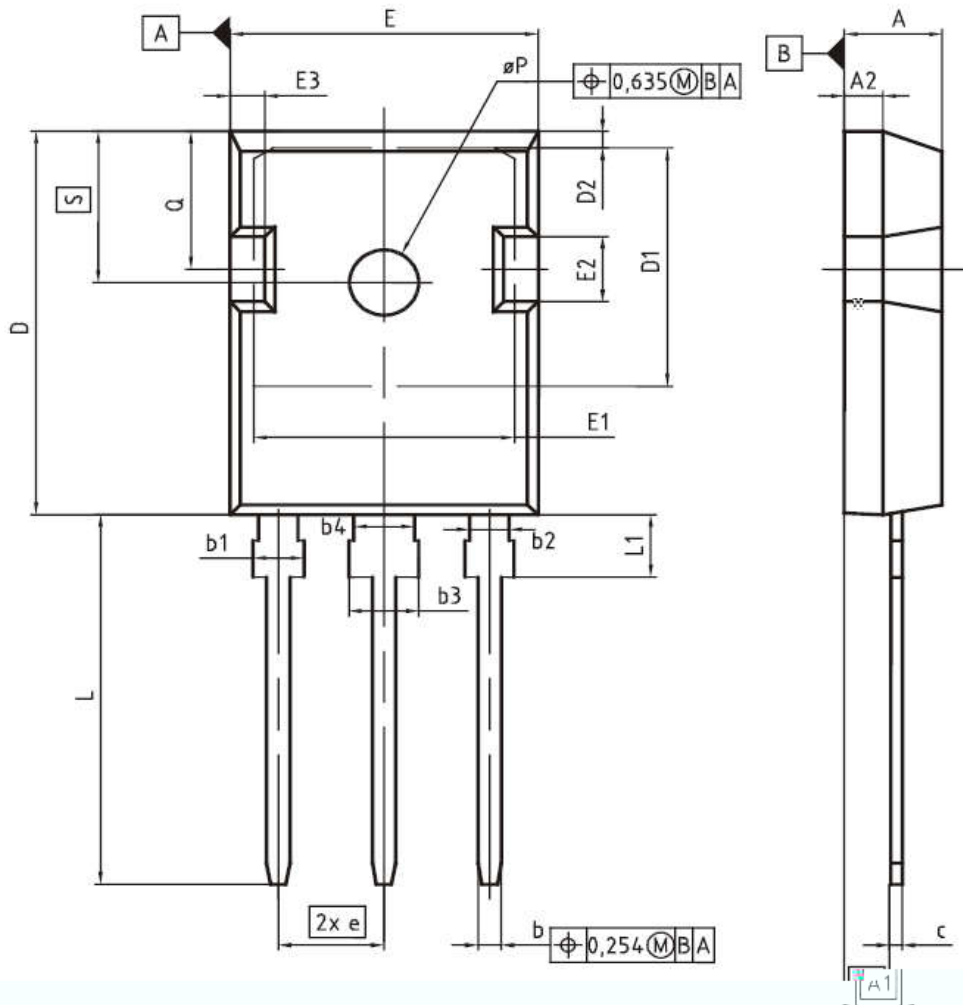
**PG-TO247-3**

DIM	MILLIMETERS		INCHES	
	MIN	MAX	MIN	MAX
A	4.83	5.21	0.190	0.205
A1	2.27	2.54	0.089	0.100
A2	1.85	2.16	0.073	0.085
b	1.07	1.33	0.042	0.052
b1	1.90	2.41	0.075	0.095
b2	1.90	2.16	0.075	0.085
b3	2.87	3.38	0.113	0.133
b4	2.87	3.13	0.113	0.123
c	0.55	0.68	0.022	0.027
D	20.80	21.10	0.819	0.831
D1	16.20	17.50	0.640	0.690
D2	0.95	1.35	0.037	0.053
E	15.70	16.13	0.618	0.635
E1	13.70	14.10	0.516	0.557
E2	3.68	5.10	0.145	0.201
E3	1.00	2.60	0.039	0.102
e	5.44 (BSC)		0.214 (BSC)	
N	3		3	
L	19.80	20.32	0.780	0.800
L1	4.10	4.47	0.161	0.176
øP	3.50	3.70	0.138	0.146
Q	5.49	6.00	0.216	0.236
S	6.04	6.30	0.238	0.248