

65V N-Ch Power MOSFET

V_{DS}		65	V
$R_{DS(on),typ}$	TO-263	2.3	m
$R_{DS(on),typ}$	TO-220	2.6	m
I_D (Silicon Limited)		181	A

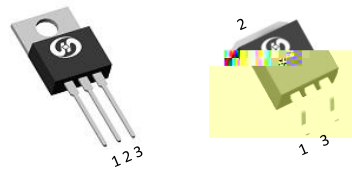
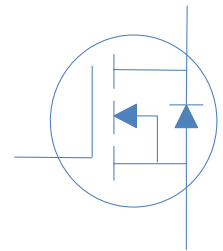

Part Number	Package	Marking
HGB028NE6A	TO-263	GB028NE6A
HGP028NE6A	TO-220	GP028NE6A

Absolute Maximum Ratings at $T_J=25^{\circ}\text{C}$ (unless otherwise specified)

Parameter	Symbol	Conditions	Value	Unit
Continuous Drain Current (Silicon Limited)	I_D	$T_C=25^{\circ}\text{C}$	181	A
		$T_C=100^{\circ}\text{C}$	128	
Drain to Source Voltage	V_{DS}	-	65	V
Gate to Source Voltage	V_{GS}	-	± 20	V
Pulsed Drain Current	I_{DM}	-	400	A
Avalanche Energy, Single Pulse	E_{AS}	$L=0.1\text{mH}, T_C=25^{\circ}\text{C}$	80	mJ
Power Dissipation	P_D	$T_C=25^{\circ}\text{C}$	172	W
Operating and Storage Temperature	T_J, T_{stg}	-	-55 to 175	$^{\circ}\text{C}$

Absolute Maximum Ratings

Parameter	Symbol	Max	Unit
Thermal Resistance Junction-Ambient	R_{JA}	60	$^{\circ}\text{C}/\text{W}$
Thermal Resistance Junction-Case	R_{JC}	0.87	$^{\circ}\text{C}/\text{W}$



Fig 1. Typical Output Characteristics

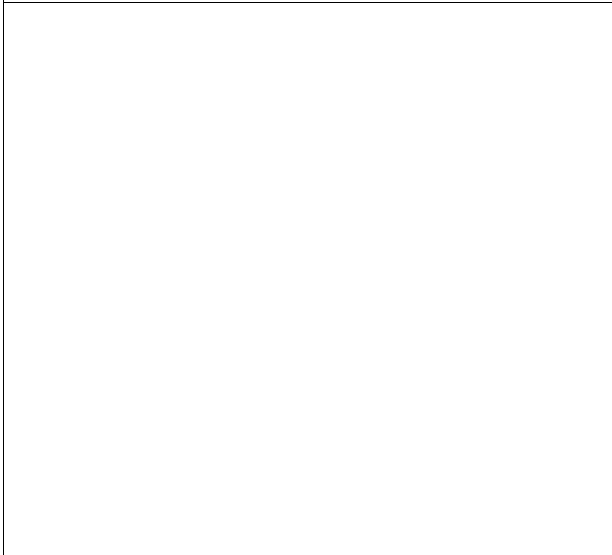

Figure 2. On-Resistance vs. Gate-Source Voltage

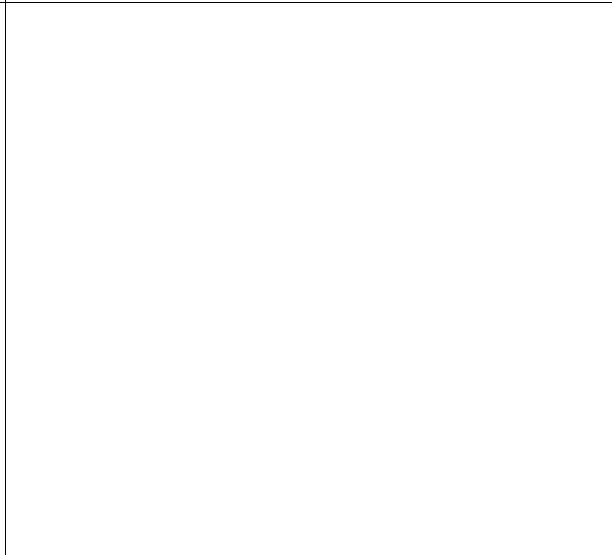

Figure 3. On-Resistance vs. Drain Current and Gate Voltage

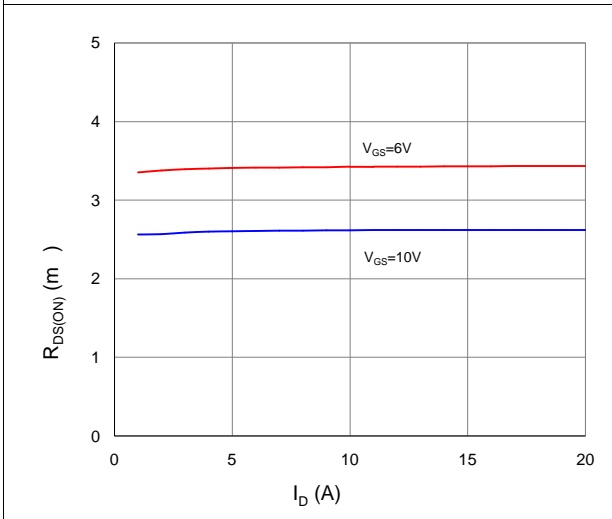

Figure 4. Normalized On-Resistance vs. Junction Temperature

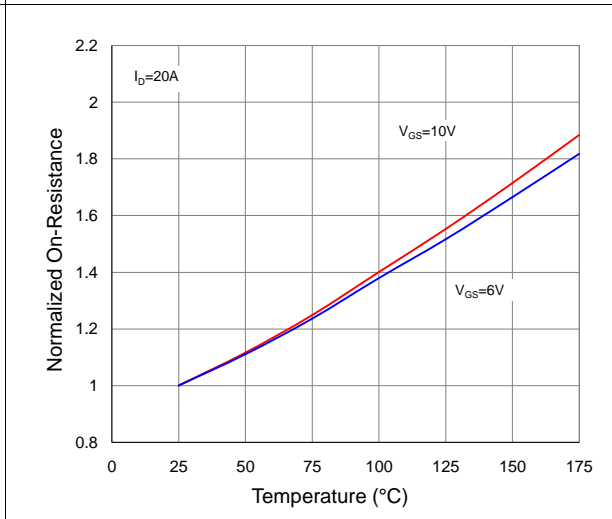

Figure 5. Typical Transfer Characteristics

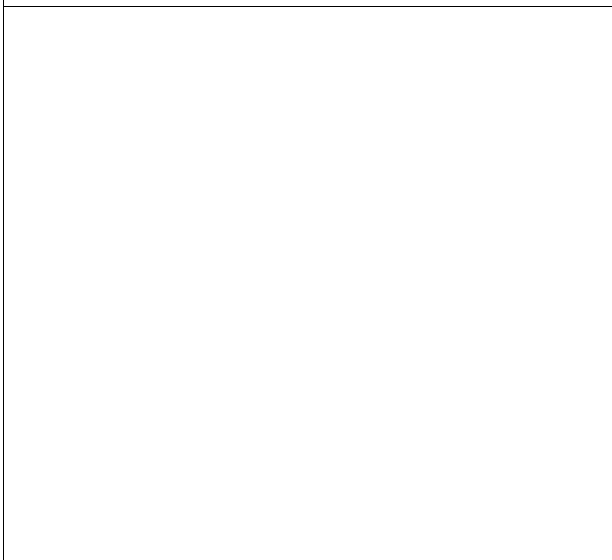

Figure 6. Typical Source-Drain Diode Forward Voltage

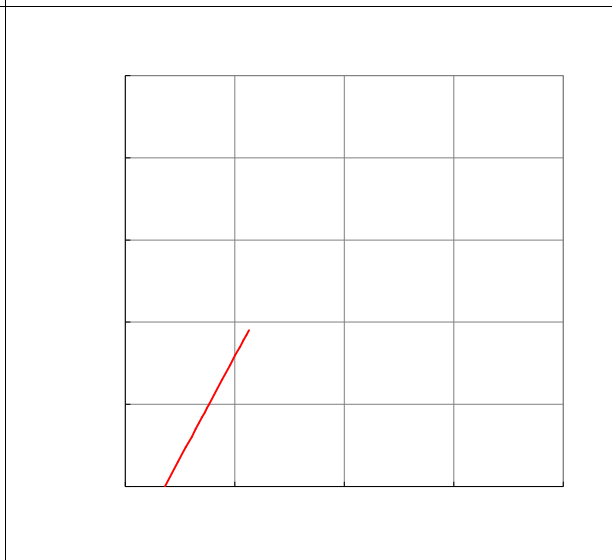

Figure 7. Typical Gate-Charge vs. Gate-to-Source Voltage

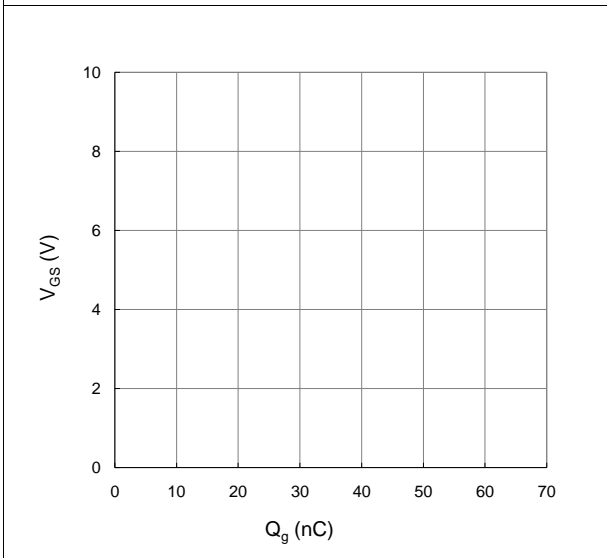

Figure 8. Typical Capacitance vs. Drain-to-Source Voltage

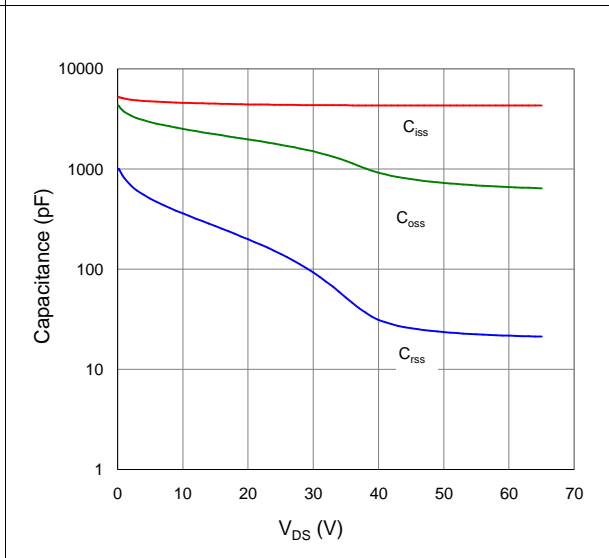

Figure 9. Maximum Safe Operating Area

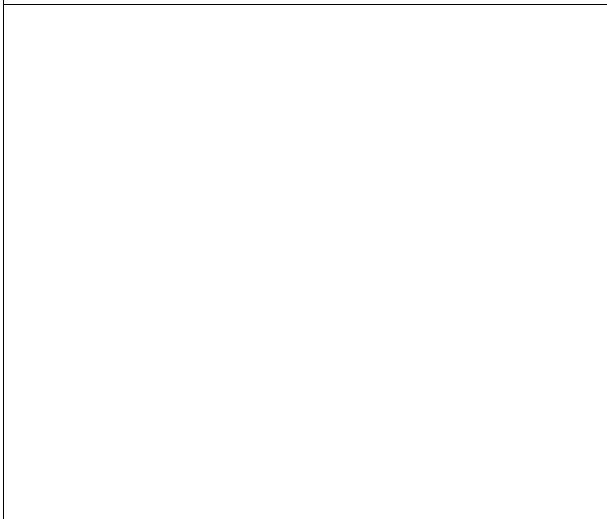

Figure 10. Maximum Drain Current vs. Case Temperature

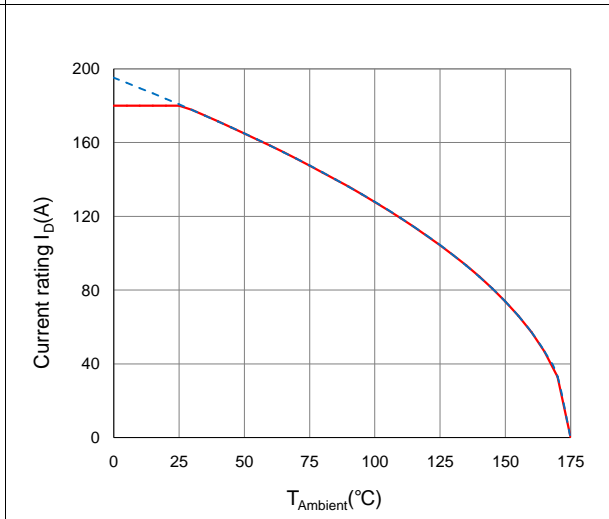
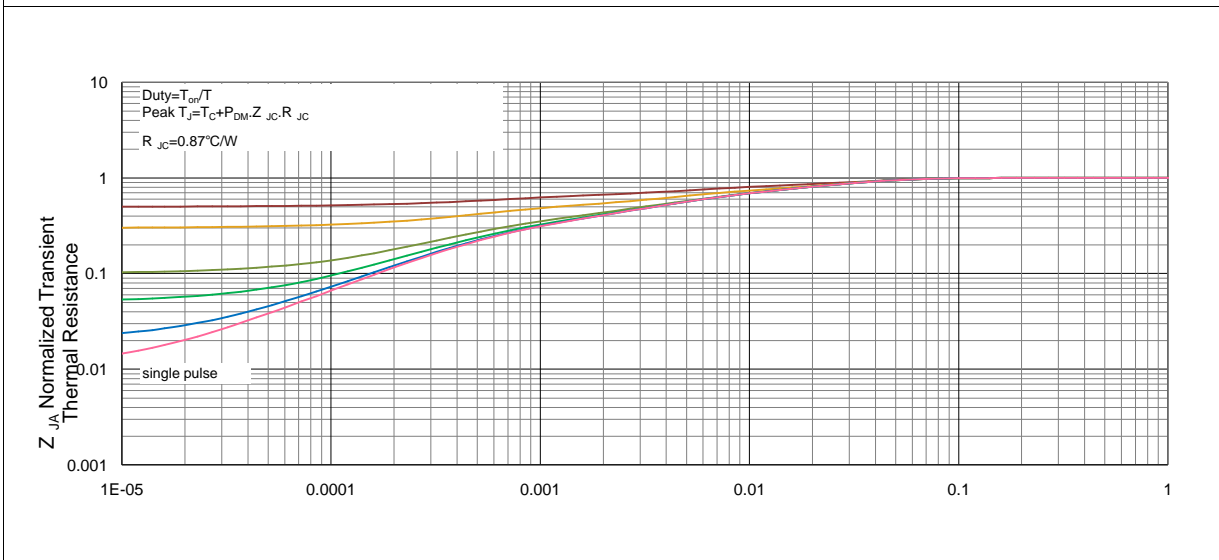
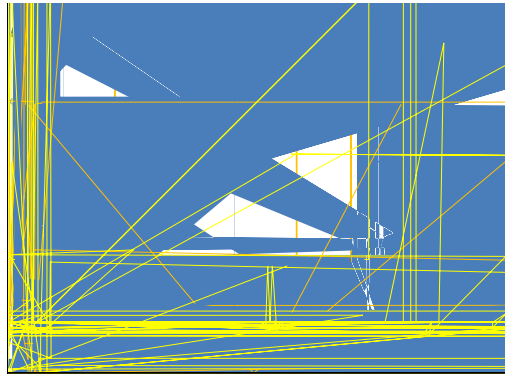
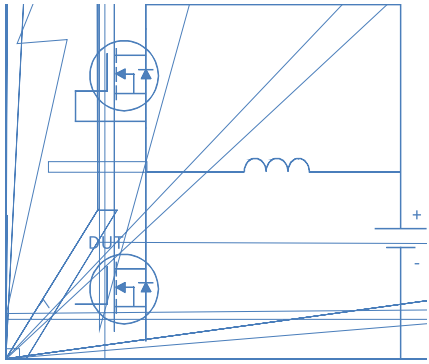

Figure 11. Normalized Maximum Transient Thermal Impedance, Junction-to-Ambient



Inductive switching Test



Gate Charge Test

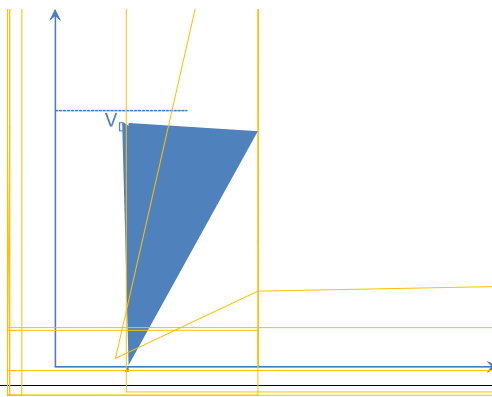

Uclamped Inductive Switching (UIS) Test

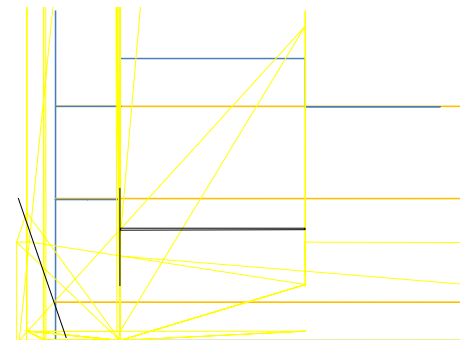
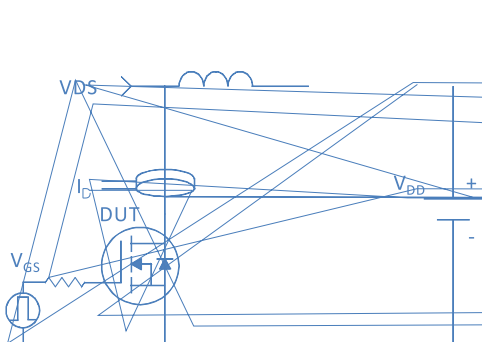

Diode Recovery Test

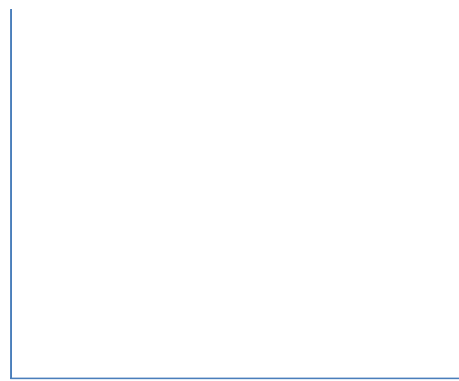
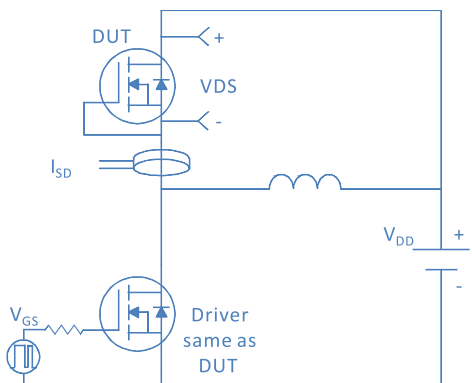

Package Outline

TO-220, 3 leads

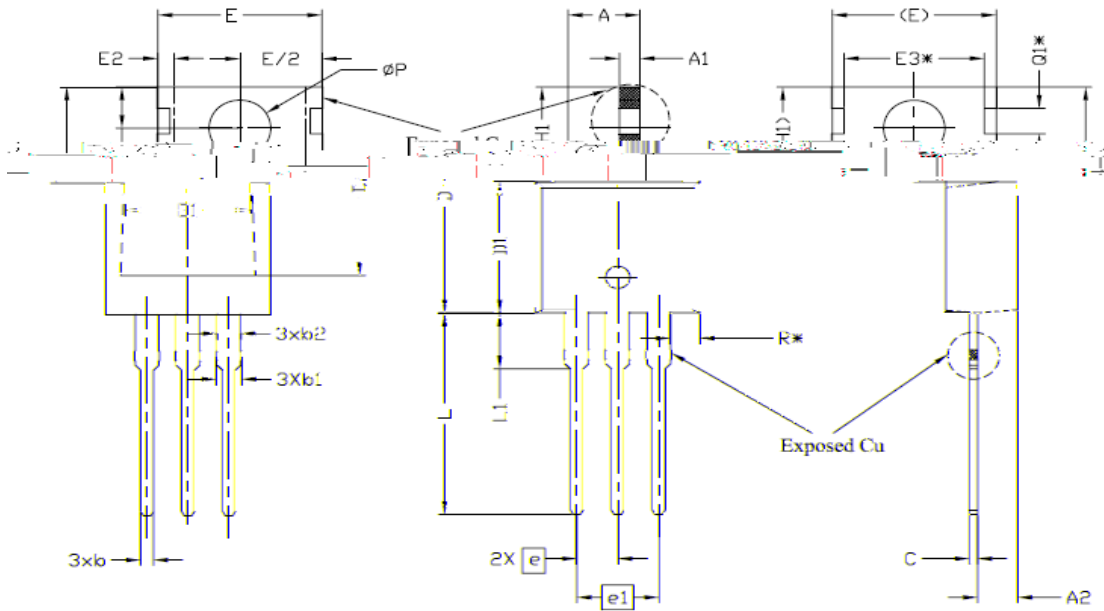

SYMBOL	DIMENSIONS			NOTES
	MIN.	NOM.	MAX.	
A	1.27	3.30	3.93	
A1	1.14	1.00	0.85	
A2	0.50	1.65	0.80	
C	0.18	0.20	0.30	
C1	1.18	1.65	1.65	
E	1.78	1.65	1.65	
E1	0.10	0.20	0.20	
E2	1.27	1.27	1.65	
E3*	0.50	0.50	0.50	
E4	1.27	1.27	1.65	
E5	0.50	0.50	0.50	
E6	0.50	0.50	0.50	
E7	0.50	0.50	0.50	
E8	0.50	0.50	0.50	
E9	0.50	0.50	0.50	
E10	0.50	0.50	0.50	
E11	0.50	0.50	0.50	
E12	0.50	0.50	0.50	
E13	0.50	0.50	0.50	
E14	0.50	0.50	0.50	
E15	0.50	0.50	0.50	
E16	0.50	0.50	0.50	
E17	0.50	0.50	0.50	
E18	0.50	0.50	0.50	
E19	0.50	0.50	0.50	
E20	0.50	0.50	0.50	
E21	0.50	0.50	0.50	
E22	0.50	0.50	0.50	
E23	0.50	0.50	0.50	
E24	0.50	0.50	0.50	
E25	0.50	0.50	0.50	
E26	0.50	0.50	0.50	
E27	0.50	0.50	0.50	
E28	0.50	0.50	0.50	
E29	0.50	0.50	0.50	
E30	0.50	0.50	0.50	
E31	0.50	0.50	0.50	
E32	0.50	0.50	0.50	
E33	0.50	0.50	0.50	
E34	0.50	0.50	0.50	
E35	0.50	0.50	0.50	
E36	0.50	0.50	0.50	
E37	0.50	0.50	0.50	
E38	0.50	0.50	0.50	
E39	0.50	0.50	0.50	
E40	0.50	0.50	0.50	
E41	0.50	0.50	0.50	
E42	0.50	0.50	0.50	
E43	0.50	0.50	0.50	
E44	0.50	0.50	0.50	
E45	0.50	0.50	0.50	
E46	0.50	0.50	0.50	
E47	0.50	0.50	0.50	
E48	0.50	0.50	0.50	
E49	0.50	0.50	0.50	
E50	0.50	0.50	0.50	
E51	0.50	0.50	0.50	
E52	0.50	0.50	0.50	
E53	0.50	0.50	0.50	
E54	0.50	0.50	0.50	
E55	0.50	0.50	0.50	
E56	0.50	0.50	0.50	
E57	0.50	0.50	0.50	
E58	0.50	0.50	0.50	
E59	0.50	0.50	0.50	
E60	0.50	0.50	0.50	
E61	0.50	0.50	0.50	
E62	0.50	0.50	0.50	
E63	0.50	0.50	0.50	
E64	0.50	0.50	0.50	
E65	0.50	0.50	0.50	
E66	0.50	0.50	0.50	
E67	0.50	0.50	0.50	
E68	0.50	0.50	0.50	
E69	0.50	0.50	0.50	
E70	0.50	0.50	0.50	
E71	0.50	0.50	0.50	
E72	0.50	0.50	0.50	
E73	0.50	0.50	0.50	
E74	0.50	0.50	0.50	
E75	0.50	0.50	0.50	
E76	0.50	0.50	0.50	
E77	0.50	0.50	0.50	
E78	0.50	0.50	0.50	
E79	0.50	0.50	0.50	
E80	0.50	0.50	0.50	
E81	0.50	0.50	0.50	
E82	0.50	0.50	0.50	
E83	0.50	0.50	0.50	
E84	0.50	0.50	0.50	
E85	0.50	0.50	0.50	
E86	0.50	0.50	0.50	
E87	0.50	0.50	0.50	
E88	0.50	0.50	0.50	
E89	0.50	0.50	0.50	
E90	0.50	0.50	0.50	
E91	0.50	0.50	0.50	
E92	0.50	0.50	0.50	
E93	0.50	0.50	0.50	
E94	0.50	0.50	0.50	
E95	0.50	0.50	0.50	
E96	0.50	0.50	0.50	
E97	0.50	0.50	0.50	
E98	0.50	0.50	0.50	
E99	0.50	0.50	0.50	
E100	0.50	0.50	0.50	

Package Outline

TO-263, 3 leads

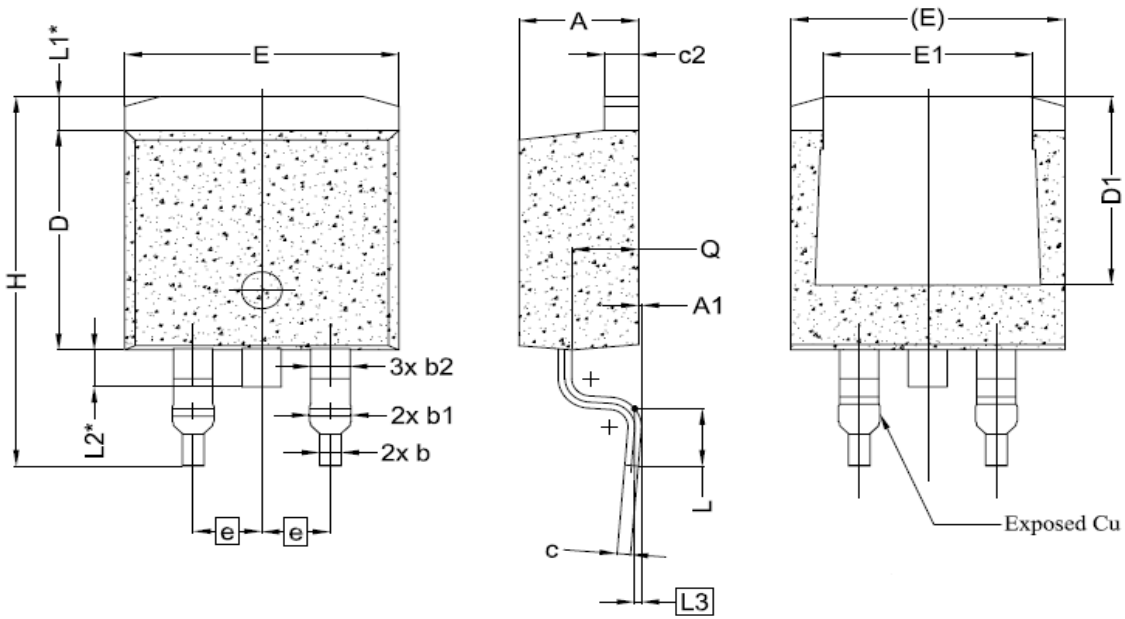

Symbol	Dimension	Value	Value	Symbol
L1*	15.00	15.00	15.00	L1
E	4.51	4.51	4.51	L2
D	2.78	2.78	2.78	L3
H	1.35	1.35	1.35	Q
L2*	1.50	1.50	1.50	c2
3x b2	0.25	0.25	0.25	Q
2x b1	0.20	0.20	0.20	A1
2x b	0.20	0.20	0.20	c
e	0.20	0.20	0.20	L3
2.54 BSC:				
4.51	15.00	15.88	H	
2.78	2.78	2.78	L	
1.35 REF.				
1.50 REF.				
0.25 BSC:				
2.30	2.48	2.70	Q	